

Bariatric/Handrail Scales



Bariatric/Handrail
Model 240-10-2



Bariatric/Handrail with Chair Seat
Model 240-10-1

STANDARD FEATURES

- Platform dimensions: 20in x 25in x 3in
- Handrails for extra support and safety
- Integrated wheels for ease of portability
- Motiontrap™ (movement compensation technology)
- Large 1 in LCD display
- Low battery indicator/automatic power-off
- BMI (body mass index) function
- Reweigh function
- Hold function
- Unit of measure: lb only, kg only, lb/kg
- RS-232 output
- Updatable firmware
- Capacity: 1000lb x 0.2lb (450kg x 0.1 kg)

Bariatric/Handrail with Chair Seat (Model 240-10-1)

- Folding seat

APPROVALS



SPECIFICATIONS

POWER:

9VDC, provided by AC adaptor or internal rechargeable battery

BATTERY TYPE:

Sealed lead acid

BATTERY USE:

75 hours
Automatic power-off can be configured from 0-20 minutes

OPERATING TEMPERATURE:

50°F to 104°F (14°C to 40°C)

APPROVALS:

CE

WARRANTY:

Two-year limited warranty

Model 240-10

| DIMENSIONS | | | |
|------------|------|----------|--------|
| A | 20in | D | 25in |
| B | 25in | E | 34in |
| C | 3in | F | 44.5in |

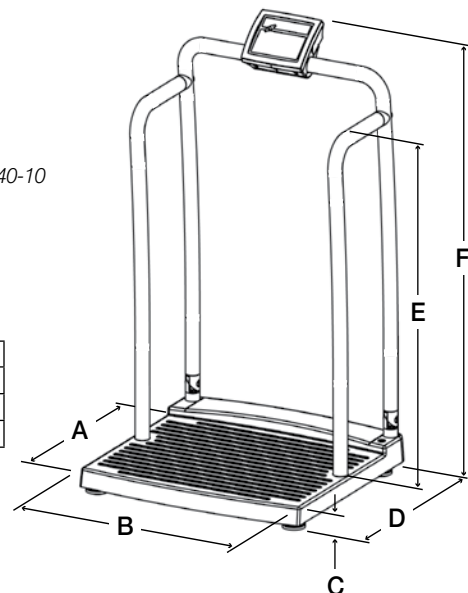

Medical/Health Scales

Bariatric/Handrail Scales

| PART # | MODEL | CAPACITY | EST. SHIP WEIGHT | PRICE |
|---|--|--|------------------|---------|
| Bariatric/Handrail | | | | |
| 112108..... | 240-10-2 | 1000lb (450kg) x 0.2lb (0.1 kg) includes 120V AC adaptor | 65lb | Consult |
| 117810..... | 240-10-2 | 1000lb (450kg) x 0.2lb (0.1 kg) includes 230V AC adaptor | 65lb | Consult |
| Bariatric/Handrail with Chair Seat | | | | |
| 110588..... | 240-10-1 | 1000lb (450kg) x 0.2lb (0.1 kg) includes 120V AC adaptor | 75lb | Consult |
| 112720..... | 240-10-1 | 1000lb (450kg) x 0.2lb (0.1 kg) includes 230V AC adaptor | 75lb | Consult |
| OPTIONS | | | | |
| 100719..... | RS-232 cable, 4 ft cable DB9 female to RJ-45 | | | Consult |
| 72704..... | USB to serial convertor | | | Consult |