



PFS

Portable Floor Scale

Technical Specification



*PFS shown with optional PC-820
and BP-25R battery pack*

DESCRIPTION

General

Take the scale to the job rather than the job to the scale.

Design

- 24" x 18" –1,000 lb deck scale
- Designed to interface with the Avery Weigh-Tronix Model PC-820 Dual Counting Scale.
- Standard 12" x 14" platform with pre-drilled holes to mount a battery operated counting scale or an indicator.
- Includes mounting hardware to hold Avery Weigh-Tronix PC-820 Counting Scale or WI-125 Weight Indicator in place.
- Includes DB9 connector to interface with the PC-820.
- Four additional pre-drilled holes designed to mount a BP-25R Battery Pack for extended battery operation.



SPECIFICATIONS

Capacity – 1,000 lbs (500 kg)

Finish – Carbon steel, high grade powder paint finish

Weight sensor – (1) 350-ohm shear beam load cell

Load Cell Output – 2mV/V

Overload Protection – 200%

End Loading – 100%

Accuracy – 0.02% of rated output

Temperature – 14 to 104°F (-10 to 40°C)

Load Cell Cable – 10 ft cable included inside column

Wheels – Polyolefin, each wheel capacity rated at 300 lbs.

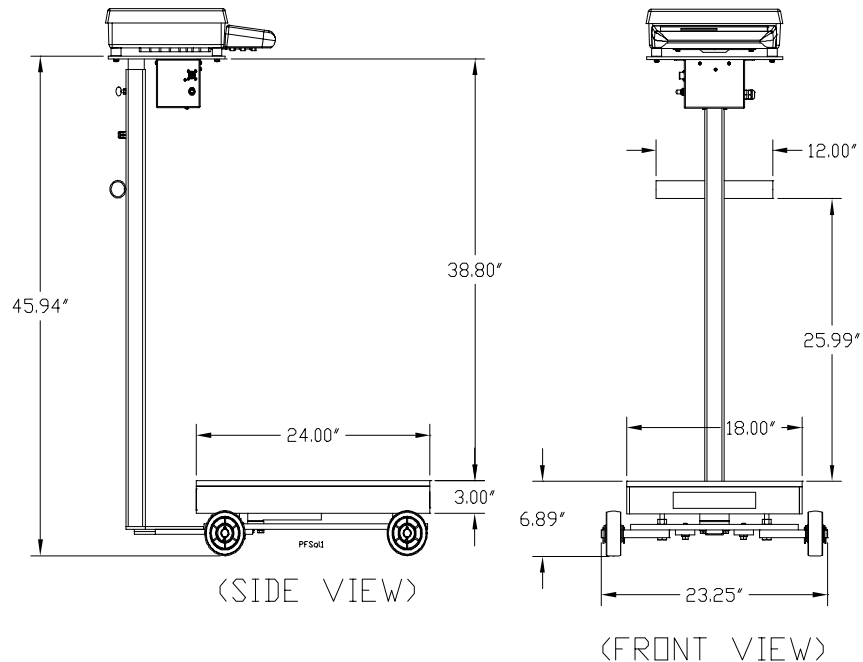
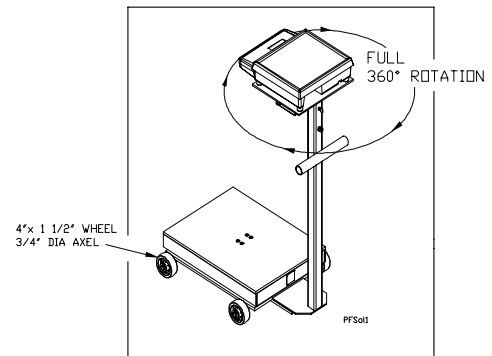
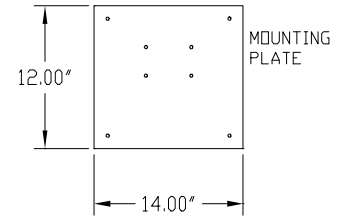

Outline drawing shown with PC-820 and BP-25R Battery Pack

Avery Weigh-Tronix - USA

1000 Armstrong Drive,
 Fairmont, MN 56031-1439 USA
 usinfo@awtxglobal.com
 Toll-Free: (800) 533-0456
 Phone: (507) 238-4461

Avery Weigh-Tronix - UK

Foundry Lane, Smethwick,
 West Midlands B66 2LP UK
 info@awtxglobal.com
 Phone: +44 (0) 8453 66 77 88
 Fax: +44 (0) 121 224 8183

Please call us or visit www.averyweigh-tronix.com
 for your nearest Avery Weigh-Tronix distributor

Avery Weigh-Tronix

