

CS Series

Electronic Crane Scales



- **Lifting-duty hardware**– Makes load connection simple and secure
- **Capacity**– 500 kg / 1000 lb
- **Sturdy Construction**– Aluminum die-cast case, alloy steel loadcell, hook and shackle
- **Visible LED Display**– Adjustable brightness for any environment
- **Dual Power**– Operate by on-board battery or while connected to charger
- **Remote Control**– Offers increased safety and convenience

VALUE IN
WEIGHING

CS Series Electronic Crane Scales

Features

Brecknell crane scales are versatile, economic solutions for overhead material handling and weighing applications.

Rechargeable Battery: Operates 20 hours between charges

Remote Control: Puts all scale functions at your fingertips

Elongated Upper Shackle: Accommodates thick hooks

Swivel Hook with Latch: Makes load connection easy and secure

Bright LED Display: Has adjustable brightness for any environment

Dual Units of Measure: Displays kg or lb

Accumulator Function: Calculates total weight

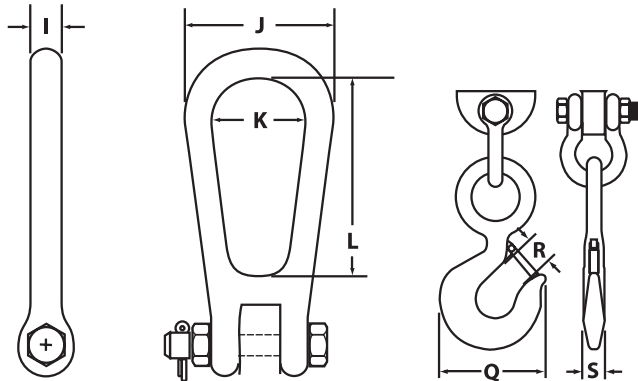

Dimensions						
I	J	K	L	Q	R	S
7/16"	1 7/8"	1"	3 1/4"	3"	7/8"	3/4"

Specifications

Capacities: 500 kg x 0.2 / 1000 lb x 0.5 lb

Accuracy: +/- 0.3% of full scale capacity

Factory Calibration: 39° latitude optimized

Power: Rechargeable battery with AC power adapter; Remote control requires two AA alkalines

Display: Five digit, 30 mm / 1.2" LED

Remote Control: Distance controls for zero, tare, hold, accumulator and power

Minimum Ultimate Safety Factor: 400%

Factory Proof Load: 125% of capacity

Typical Battery Life: 20 hours between charges (room temp)

Operating Temperature: -10° C to 40° C
14° F to 104° F

Product Dimension:

430 mm (L) x 215 mm (W) x 135 mm (D)
17.0" L x 8.5" W x 5.3" D

Shipping Weight: 6.2 kg / 13.5 lb

Packaging Dimension:

305 mm (L) x 280 mm (W) x 190 mm (H)
12" L x 11" W x 7.5" H



a division of Avery Weigh-Tronix, LLC

Brecknell

1000 Armstrong Dr., Fairmont, MN 56031
Toll free: 800-637-0529, Tel: 507-238-8702
Fax: 507-238-8271
e-mail: sales@brecknellscales.com
www.brecknellscales.com



Brecknell

Foundry Lane, Smethwick
West Midlands B66 2LP UK
Tel: +44 (0) 845 246 6717
Fax: +44 (0) 845 246 6718
Email: sales@brecknellscales.co.uk
www.brecknellscales.co.uk

