

DORON

PC-400

Portion Control Scale



PC-400 Features...

- Exclusive "Quad Spring" Shockproof Design
- AC Power and Rechargeable Battery Included
- Stainless Steel Case and Platter

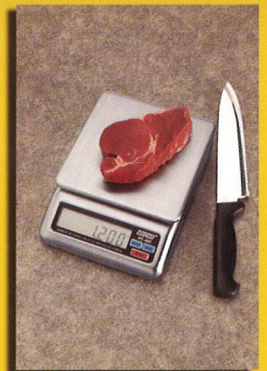
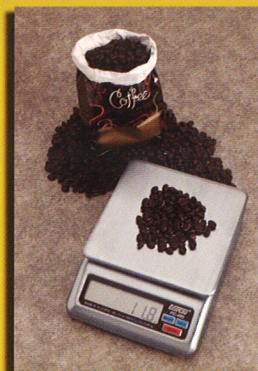



PC-400

Portion Control Scale

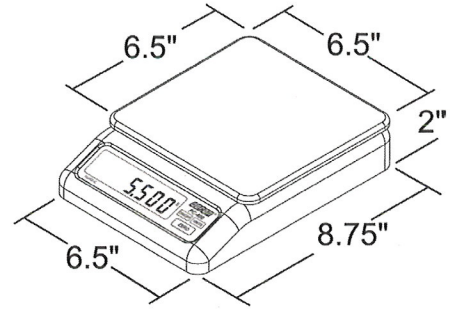

Doran proudly introduces the new PC-400 Portion Control Scale, the most feature-packed, heavy-duty scale in its class. With a surprisingly low price, the PC-400 is the result of responding to your needs, utilizing Doran's experience of over 30 years of reliable and innovative scale designs. The rugged PC-400 makes the "throw-away" portion control scale a thing of the past.

Rugged: The PC-400 includes our field proven, exclusive "Quad-Spring" base design that virtually eliminates damage from shock and overload.

AC/DC: The choice is yours - use the AC plug-in power adapter, or the included internal rechargeable battery for total portability. Recharge the battery in less than 4 hours with the included AC adapter - you can even use the PC-400 while recharging!

Easy to Clean: The case and removable platter are constructed of food grade 304 Stainless Steel.

Compact: The small size of the PC-400 allows it to be used in tight spaces, and lets you move your scale to the work with ease.

Experience Doran Quality & Reliability

Order a new **PC-400 Portion Control Scale** today!

Five-Way Weight Display

Display samples below show the same weight (5lb 8oz) in 5 different units. Press UNITS to select the weight display that best suits your needs.

Pounds & Ounces

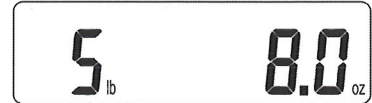

Pounds



Ounces



Kilograms



Grams



Technical Specifications:

- Display:** LCD 0.66" High - Wide Viewing Angle
- Controls:** ZERO(TARE), ON/OFF & UNITS
- Indicators:** Negative Weight, Motion, Low Battery and Weighing Units
- Units:** lb, kg, g, oz, or lb:oz
- Output:** Bi-directional RS-232 (standard)
- Power:** AC & DC Power Standard
115V AC Adapter, 6' cord
Rechargeable Battery, 15 hour life
- Case/Platter:** 304 Stainless Steel
- Feet:** Four Adjustable, plus a bubble level
- Warranty:** Scale - 1 Year Parts and Workmanship
Battery - 90 Days Parts and Workmanship

Model No.	Capacity		
	lb	g	oz
PC400-02*	2.2 x 0.0002	1000 x 0.1	35 x 0.005
PC400-02LFT	2.2 x 0.001	1000 x 0.5	35 x 0.02
PC400-05	5 x 0.002	2300 x 1	80 x 0.05
PC400-10	10 x 0.005	4500 x 2	160 x 0.1
PC400-20	20 x 0.01	9100 x 5	320 x 0.2

* Not Legal for Trade

Also displays in lb:oz

Resolution:

2LFT, 5, 10 & 20 LB Models: 2500d Factory Set (NTEP)
5000d & 10,000d User Selectable
2 LB Model: 10,000d Grams Mode (not NTEP)

Approvals:



CC # 04-039A1
Class III/2500d

AC Adapter

DORAN® Doran Scales, Inc.
1315 Paramount Parkway Batavia, IL 60510



Toll Free 800-262-6844 • 630-879-1200
Fx: 630-879-0073 • www.doranscales.com
SBRC0062