



Digital Field Test Scale



Portable Precision Ready for the Field

The OHAUS Digital Field Test Scale is designed for precise material testing in the construction industry. With a capacity of 165 lb and readability up to 0.05 lb, you won't have to sacrifice precision for portability. Key features include the durable metal carrying case and internal battery with a 70-hour life between recharges, making the Field Test Scale a powerful addition to any job site.

Standard Features:

- **Designed for Precise In-the-Field Weighing**

A capacity of 165 lb with a readability of 0.05 lb and the painted steel base in a case means that the Digital Field Test Scale provides precise, clear measurements, no matter where you're working.

- **Packaged in a Durable Metal Case with Handle for Protection and Portability**

The Field Test Scale comes packaged in a durable metal carrying case with steel latches and carrying handle, ensuring maximum portability for use anywhere on the job—without limiting you to the lab.

- **Equipped with a Range of User-Friendly Features**

The backlit LCD display allows for easy reading of results—even in low-light conditions. The internal battery means that you can operate for up to 70 hours between recharges.

Digital Field Test Scale

Model	D31P75SD
Capacity × Readability	165 lb × 0.05 lb / 75 kg × 0.02 kg
Resolution	1:3,000
Base Size (L × W × H)	12.4 × 11 × 1.77 in. / 316 × 280 × 45 mm
Construction	ABS plastic indicator housing, painted steel base with raised, embossed tread platform, metal carrying case with foam insert and latches
Weighing Units	lb, kg, oz, g, lb:oz (lb and kg default)
Application Modes	Weighing, Counting
Display	6-digit, 7-segment LCD 1 in. / 25 mm digit height, with high-contrast white LED backlight
Keyboard	4-button mechanical switches, raised tactile keys
Communication	Bi-directional RS232 (included)
Stabilization Time	Within 3 seconds
Indicator Cable Length	9 ft.
Operating Temperature	41 °F to 104 °F / 5 °C to 40 °C / 10%–80% relative humidity, non-condensing
Power	9 VDC, 0.5A, AC adapter or internal rechargeable, sealed lead-acid battery
Battery Operating Time	100 hours of typical operation with full charge
Auto-Shut Off	Selectable—Off, 1, 2, or 5 minutes of no activity
Safe Overload Capacity	150% of capacity
Carrying Case Size (L × W × D)	15 × 7 × 13.5 in. / 381 × 178 × 343 mm
Shipping Dimensions (L × W × D)	15.8 × 14.4 × 8.3 in. / 400 × 365 × 210 mm
Net Weight	16.3 lb / 7.4 kg
Shipping Weight	17.6 lb / 8 kg

Other Standard Features and Equipment

ABS plastic indicator with reinforced housing, durable painted steel platform with raised embossed tread, flexible coiled cable (extendable up to 9 ft.), backlit LCD with fast weight display, AC adapter with 9 ft. cord, in-use cover for indicator included, rechargeable battery (included), RS232 interface, 150% overload protection, selectable span calibration points, auto-zero tracking, battery-saving auto-off, Geo Code geographical gravity calibration adjustment, and software menu lockouts

Compliance

- **Product Safety:** CAN/CSA C22.2 60950-1; UL 60950-1; IEC/EN 61010-1
- **Electromagnetic Compatibility:** Canada ICES-003 Class B; FCC Part 15 Class B; IEC/EN 61326-1 Class B, Basic environments
- **Compliance Marks:** CE, cULus; RCM

Accessories

RS232 Interface Cable to PC 25-pin80500524
RS232 Interface Cable to PC 9-pin80500525
Printer, Impact, SF40A, AM30064203
Printer, Thermal, STP-103, US80251992
In-Use Cover30101017
Interface Kit, RS232-USB30304101
Interface Kit, RS232-Ethernet30304102

Dimensions

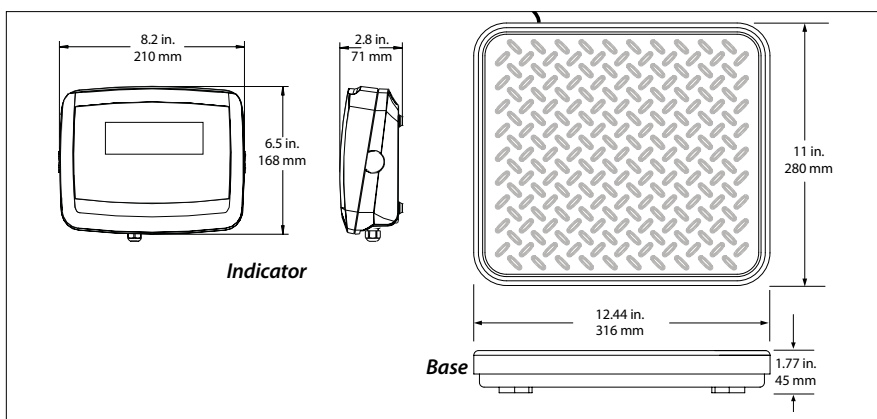

OHAUS CORPORATION

7 Campus Drive
Suite 310
Parsippany, NJ 07054 USA

Tel: 800.672.7722
973.377.9000
Fax: 973.944.7177

www.ohaus.com

The management system governing the manufacture of this product is ISO 9001:2015 certified.

