

3900LP Bench Series

With SBI 110 LCD Indicator



- **Approval**– NTEP 5000d approved electronic bench scale in pole mounted Indicator
- **Usability**– Ideal for a wide range of general weighing and warehouse/shipping applications. Functions include weighing, counting and check weighing
- **Construction**– Carbon steel fabricated frame with food grade 304 stainless steel top pan and NTEP approved, ABS housed indicator
- **Display**– Large 2" x 6.5" / 50 mm x 165 mm easy-to-read blue backlit display with 1.6" / 40 mm high digits
- **Power**– AC adapter with built-in rechargeable battery with up to 107 hours battery life between charges
- **Capacity**– 100 lb / 60 kg, 250 lb / 150 kg, 600 lb / 300 kg
- **Platform Dimension**–
 - 15.7" x 15.7" / 40 cm x 40 cm
 - 15.7" x 19.7" / 40 cm x 50 cm
 - 19.7" x 23.6" / 50 cm x 60 cm

VALUE IN
WEIGHING

3900LP Bench Series Calibrated with SBI 110 LCD Indicator

Features

The 3900LP electronic bench base is an NTEP approved 5000 division bench base scale with a pole mounted indicator that can be used for a wide range of general purpose floor or bench base applications.

General Weighing: Designed to weigh in lb, kg or pieces, the 3900LP can easily be set into sample mode - ideal for counting a wide range of medium sized components.

Check Weighing & Check Counting: Ideal for guaranteeing product or box quantities are within an agreed weight or count size and for repetitive packing applications

Base Construction: 150% overload protection, these powder coated base frames are constructed using a carbon steel tubular fabricated frame with four corner stops for extra load cell protection. The base frame is fitted with four large lockable adjustable anti-slip feet ideal for leveling the base if positioned on uneven ground.

Load Cell: This base is fitted with a robust, approved, aluminum IP65 (NEMA 4) load cell

Top Pan : The base is fully covered with a removable hard-wearing, food grade 304 stainless steel top pan

Indicator Construction: The ABS housed Brecknell SBI 110 Indicator with its large, easy-to-read 2" x 6.5" LCD back lit display and built-in battery allows this product to be used in low lit areas or in areas where power outlets are hard to find. The 3900LP Bench Scale can provide over 107 hours of battery life between charges.

Specifications

Capacity and Dimension:

Capacity	Dimension (in)	Dimension (cm)
100 lb x 0.02 lb / 45 kg x 0.01 kg	15.7 x 15.7 x 5.3	40 x 40 x 12
250 lb x 0.05 lb / 113 kg x 0.02 kg	15.7 x 19.7 x 5.7	40 x 50 x 15
600 lb x 0.2 lb / 272 kg x 0.1 kg	19.7 x 23.6 x 5.7	50 x 60 x 15

Accuracy: 5000d NTEP approved

Unit: lb, kg

Main Functionality: General weighing, check weighing, and check counting with audio under, accept and over buzzer

Display: Large 2" x 6.5" / 50 mm x 165 mm LCD display with five 1.6" / 40 mm high digits and blue back lit display

Operator Keys: Units, Select, Print, Zero, Tare

Power: Removable AC power adapter (included) along with a built-in, rechargeable lead acid battery to give over 107 hours of battery life between charges

Operating Temperature: 14° F to 104° F / -10° C to 40° C

Pole Dimension: 25.5" / 650 mm high

Packaging Dimension (L x W x H):

Capacity	Dimension (in)	Dimension (cm)
100 lb / 45 kg	31.3 x 20.7 x 6.5	76.5 x 52.5 x 16.5
250 lb / 113 kg	35.2 x 20.7 x 6.5	89.5 x 52.5 x 16.5
600 lb / 272 kg	38.7 x 24.6 x 7.2	98.5 x 62.5 x 18.5

Shipping Weight:

100 lb / 45 kg	28.7 lb / 13 kg
250 lb / 113 kg	32 lb / 14.5 kg
600 lb / 272 kg	58.3 lb / 26.5 kg

Certifications: Indicator 5000d NTEP CC #18-125, base 5000d NTEP CC #18-124

Capacity	A (in/mm)	B (in/mm)	C (in/mm)	D (in/mm)	E (in/mm)	F (in/mm)	G (in/mm)	H (in/mm)	I (in/mm)	J (in/mm)	K (in/mm)
100lb/45kg	9.82 / 250	15.7 / 400	13.46 / 342	20.5 / 521	13.46 / 342	15.7 / 400	1.26 / 32	35.55 / 903	7.48 / 190	3.93 / 100	3.9 / 99
250lb/113kg	9.82 / 250	19.7 / 500	17.40 / 442	24.5 / 621	13.46 / 342	15.7 / 400	1.26 / 32	35.55 / 903	7.48 / 190	3.93 / 100	3.9 / 99
600lb/272kg	9.82 / 250	23.6 / 600	21.33 / 542	28.4 / 721	17.40 / 442	19.7 / 500	1.26 / 32	35.55 / 903	7.48 / 190	3.93 / 100	4.9 / 124

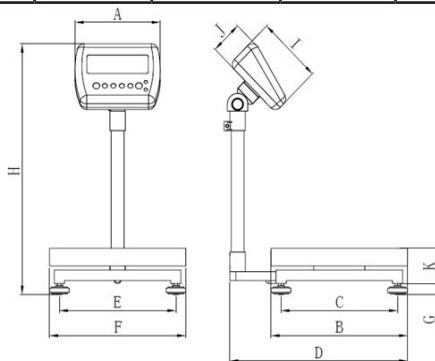

a division of Avery Weigh-Tronix, LLC

Brecknell

1000 Armstrong Dr., Fairmont, MN 56031
Toll free: 800-637-0529, Tel: 507-238-8702
Fax: 507-238-8271
e-mail: sales@brecknell scales.com
www.brecknell scales.com



Brecknell

Foundry Lane, Smethwick
West Midlands B66 2LP UK
Tel: +44 (0) 845 246 6717
Fax: +44 (0) 845 246 6718
Email: sales@brecknell scales.co.uk
www.brecknell scales.co.uk

